

Parallels Summit 2011

Profit from the Cloud™



Parallels Automation Roadmap for 2011

Oleg Melnikov, SVP Automation



Parallels Automation in 2010



Goals We Set for 2010

More services

More efficient services

Better stability & performance



Microsoft Exchange 2010 Enterprise

Released 2 months before the “official” Exchange 2010 for Hosters

- Based on HMC provider created by Parallels

Supports Public Folders

Shares AD Domain with Exchange 2007

Smooth migration from Exchange 2007:

- On customer discretion:
Customer upgrades subscription through the store
- On provider discretion:
Moving multiple customer organizations at once
- Migrates Blackberry accounts

The screenshot displays the Service Director web interface. On the left is a navigation tree with categories like Demo Provider, Infrastructure Director, Operations Director, and Service Director. Under Service Director, 'Organizations' is highlighted. The main content area shows a table of organizations with columns for ID and Name. A search bar is at the top, and a button for 'Upgrade to Next Exchange Version' is visible. The table lists 199 organizations, with the first few including 'Horns-Hooves3', 'Horns-Hooves2', 'Horns-Hooves1', 'Horns-Hooves', 'Max Belov5', 'ID Soft', 'TeraSky', 'Artiom Zharsky5', 'Igor Tiutiunnik4', 'Test whitespace_1', 'Test whitespace', 'David Smith', 'Cellcom_1', 'CloudBase2', 'Cellcom', 'TCStudent01 Carter', 'Nick White', 'Chris Miller1', 'Tadiran Demo', 'CloudBase1', 'CloudBase', 'Demo Reseller3', and 'Grace Zou'.

ID	Name
18751	Horns-Hooves3
18731	Horns-Hooves2
18711	Horns-Hooves1
18694	Horns-Hooves
18655	Max Belov5
18601	ID Soft
18559	TeraSky
18539	Artiom Zharsky5
18538	Igor Tiutiunnik4
18522	Test whitespace_1
18521	Test whitespace
18460	David Smith
18451	Cellcom_1
18444	CloudBase2
18410	Cellcom
18393	TCStudent01 Carter
18373	Nick White
18283	Chris Miller1
18255	Tadiran Demo
18237	CloudBase1
18235	CloudBase
18197	Demo Reseller3
18187	Grace Zou



2010 – Voice Integration

Exchange 2007 Unified Messaging

- Voice Mail: leaving, reading
- Voice access to text messages: listen to, reply, hide, delete
- Voice access to calendar items: accept/decline, report delay

OCS 2007 R2 Telephony Integration:

- Enterprise Voice: direct connect to SIP trunking
- Remote Call Control (RCC): integration with external PBX



Parallels BPOS Syndication

Benefits for Providers

- No upfront investments
- Collects payments, bills for subscription
- Quickly launch BPOS services
- Ease of creating new service bundles from different Offers
- Bundle Office365 with other services in the one package
- Provision an extendable set of Office 365 services



TDC in Denmark and
RISC IT in France
have launched already

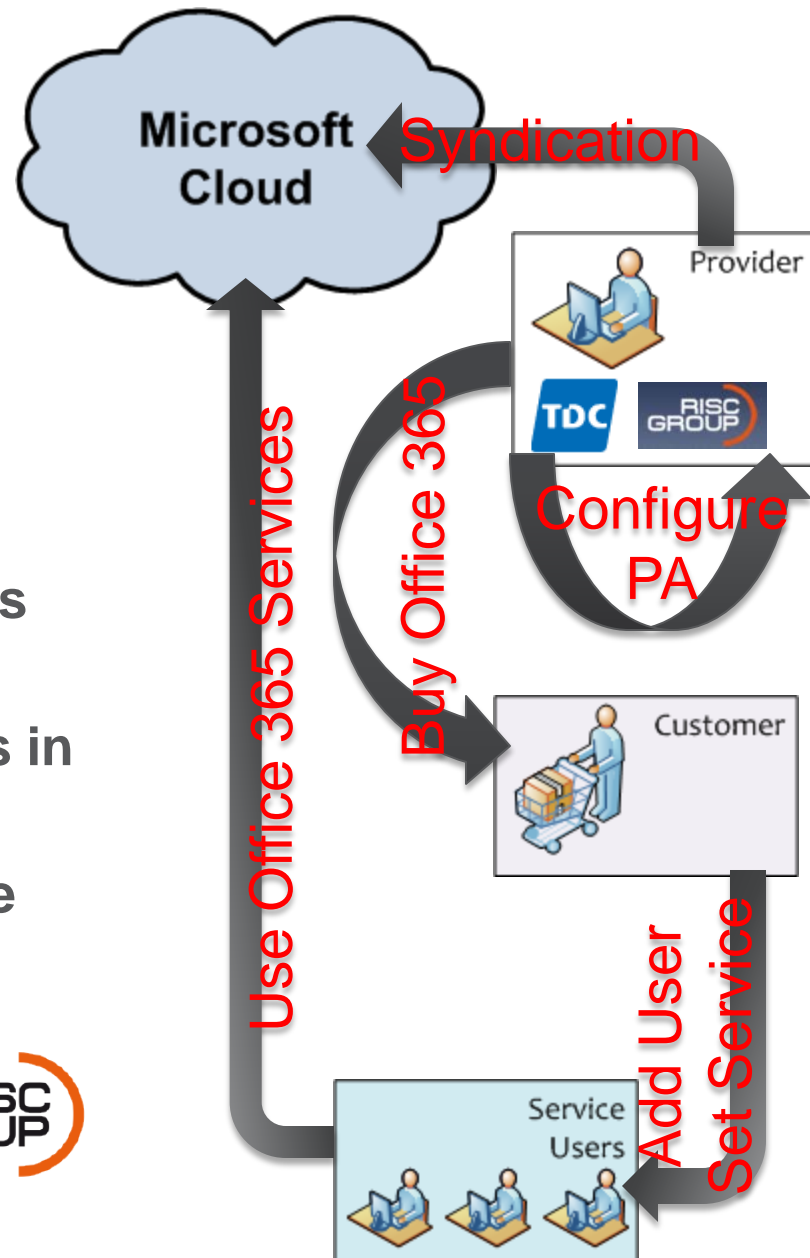

Parallels BPOS Syndication

Benefits for customers and users

For Customers:

- Easy to setup
- Easy to register and configure domains
- Configure Office 365, create Users

For End-Users:

- Easy access to the Office 365 Admin Portal
- Easy access to Outlook Web Access
- Easy access to services

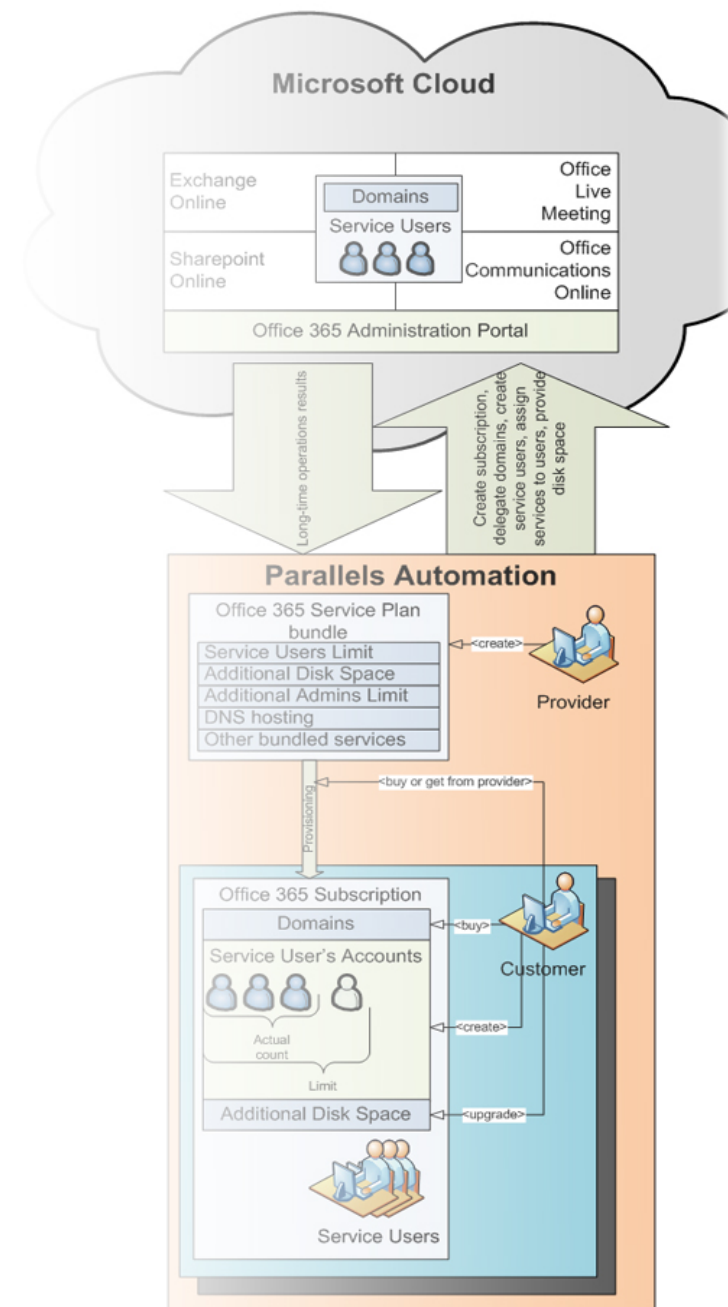

Parallels BPOS Syndication

Existing Features and Limitations

Support of basic BPOS services:

- Exchange Online
- SharePoint Online
- Office Communications Online
- Live Meeting Online

Easy User creation

Batch import users (limited)

Limitations (BPOS):

- No Blackberry support
- No Trial Subscriptions support

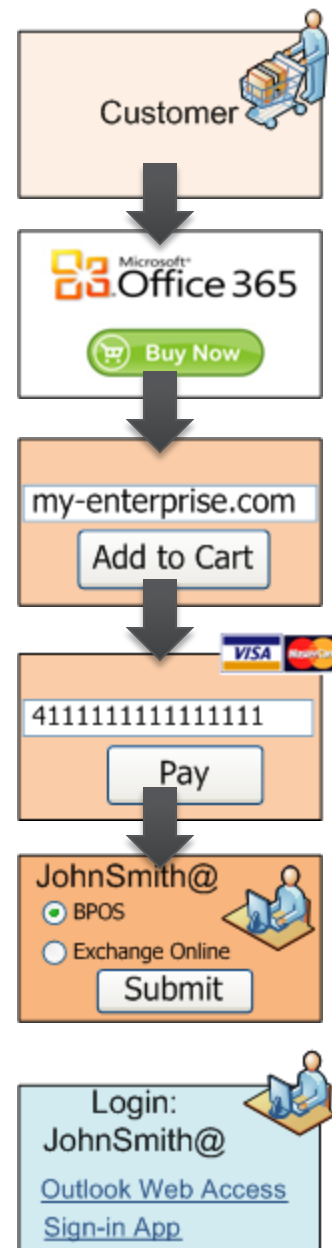

Shared Hosting Next Generation

Shared Hosting Became a Commodity

- Customers expectations grow, but prices decrease
- Offer reliable and resilient Web Hosting at lower costs

Shared Hosting NG - delivering higher service levels at lower costs

- **Improves service quality** (reliability, stability, performance)
- **Decreases support costs** (sites load monitoring, sites isolation)
- **Reduces churn** with improved reliability and planned/unplanned downtime
- Improves CAPEX with **5x higher density**

Drive efficiency to accelerate growth

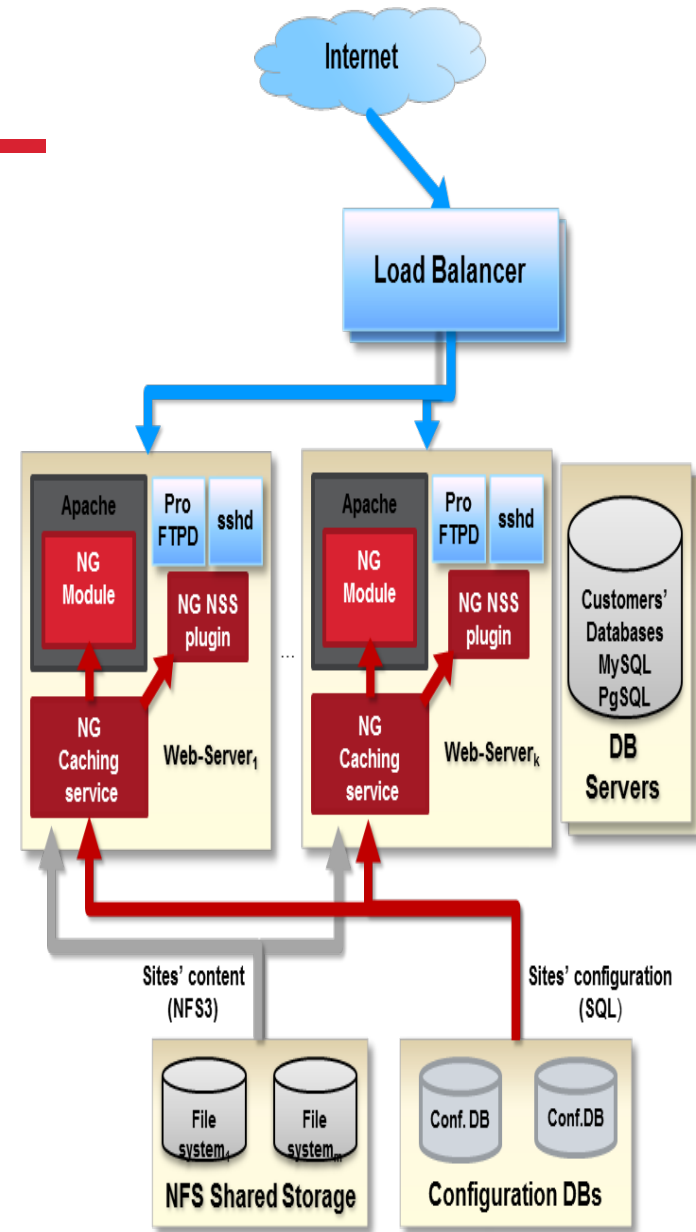

Shared Hosting Next Generation

Close to VPS isolation with simplicity of Shared Hosting

- Lightweight Virtual Environments (LVE) based on Open-VZ kernel
- Every site is limited by CPU, RAM, bandwidth
- VPS like fair CPU scheduling
- Different site limits/SLA for different users

Simple Maintenance

- Zero Downtime Maintenance
- Seamless capacity management
- Top resource consumers reporting

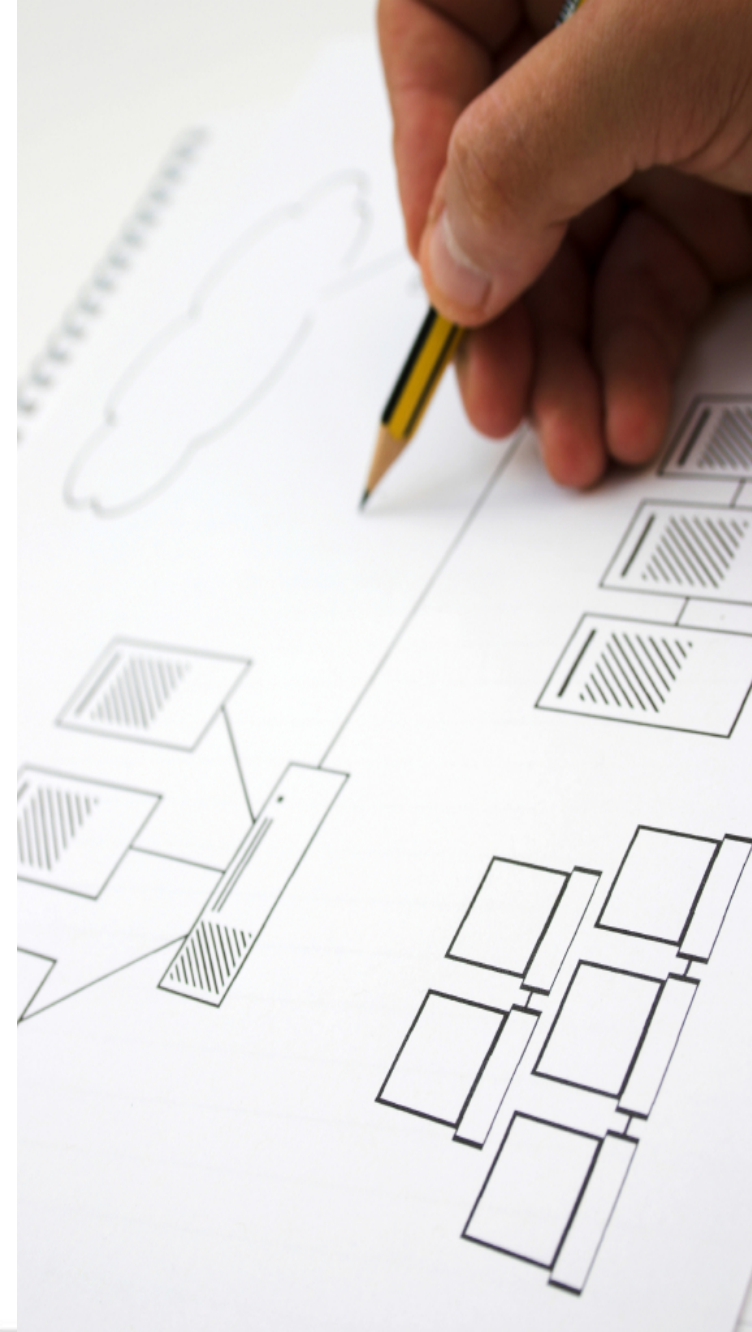

Shared Hosting Next Generation

High availability and increased stability

- Achieve up to 99,999% availability
- Performance degradation on overload instead of faults

Reduce OPEX

- By consolidating servers with 5-10x in density of websites
- With very simple servers upgrade and replacement

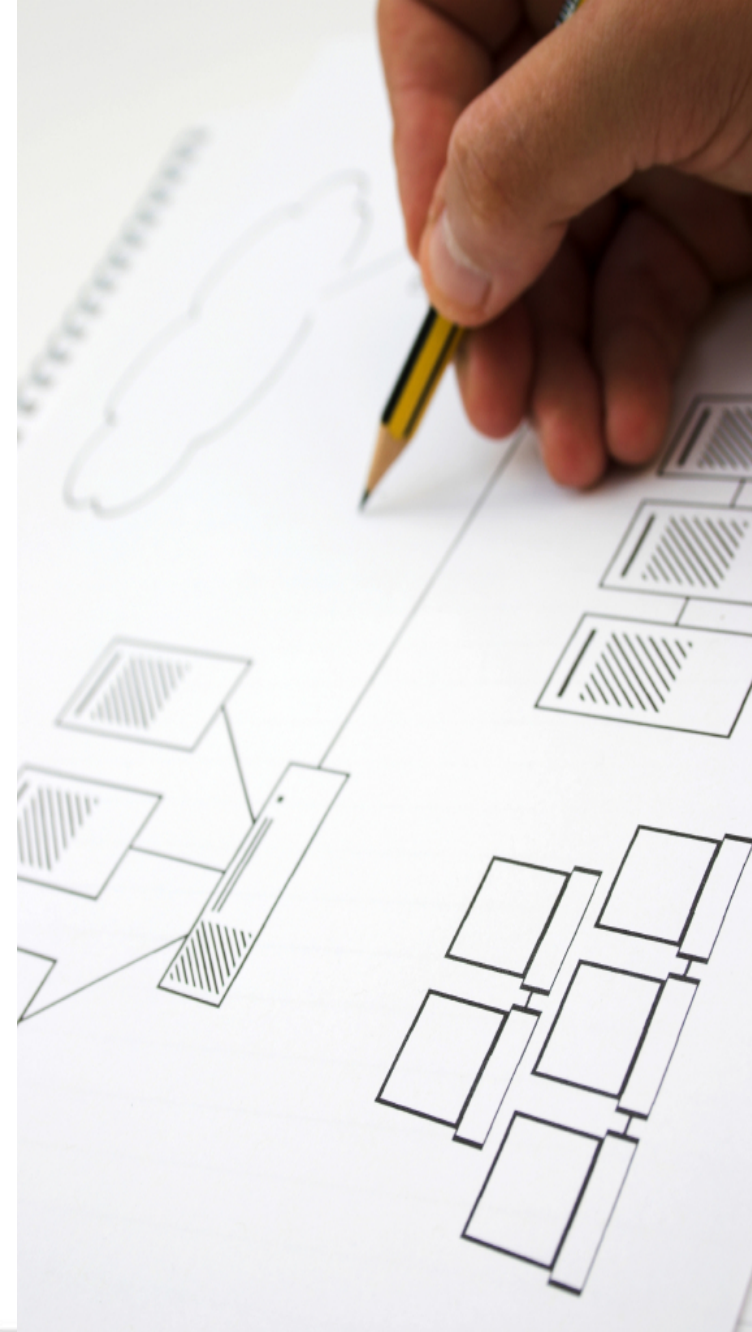

Microsoft Hyper-V Cloud

Hyper-V Cloud

- Self-Service and IT Management
 - Microsoft System Center
- Virtualization
 - Windows Server Hyper-V
- Integration Framework
 - Dynamic Datacenter Toolkit for Hosters

In Parallels Automation

- Fully automated solution for Hyper-V based Cloud Servers

First functionality set is released Dec 2010

- Integration with System Center Web Interface
- Sell/upsell “service packages”
 - Unified VM size measure – quota points
 - “Service package” – amount of quota points (technically SCVMM Role)



Microsoft Hyper-V Cloud

Access to MS SC Self-Service Portal

Parallels Automation

Subscription: 1010630

Configuration & Admin...

- Domain Overview
- Microsoft Hyper-V**
 - About
 - Management
- Statistics & Analysis

Hyper-V Account (Account ID: 1002872)

All Domains | Hosting | My Account | Help & Support | Billing

Logout

Parallels

Screen ID: 2.12.12.06.01 Refresh

Hosting » Configuration & Administration » Microsoft Hyper-V

Management

Use Microsoft Hyper-V Virtual Machine Manager to create, remove and configure your Virtual Machines.

Virtual Machine Manager	Login ↗	Change
Status	Ready	
Login	PRL4\hv_demo_account	
Password	Wilm6zP	

Service Package	Hyper-V Hosting - Basic (Run up to 10 Microsoft Windows Server 2008 R2 Virtual Machines just for \$200 a month)	Change
------------------------	---	------------------------

VMs are managed in Self-Service Portal

Service Package defines:
VM Templates, and
Amount of available resources (quota points)



Microsoft Hyper-V Cloud

Access to MS SC Self-Service Portal

The screenshot displays the Microsoft System Center Virtual Machine Manager 2008 R2 interface. The user is logged in as PRL4\hv_demo_account. The interface shows a table of virtual machines and a context menu for the selected VM.

VM Name	Status	Owner	Memory	Disk	Date Deployed	Quota
my VM	Running	PRL4\hv_demo_account	1 GB	8 GB	14.02.2011	2

The context menu for the selected VM includes the following options:

- Create
 - New Computer
- Actions
 - Start
 - Stop
 - Pause
 - Shut Down
 - Checkpoints
 - Properties
 - Store
 - Remove
 - Connect to VM
 - Remote Desktop



Microsoft Hyper-V Cloud Self-Service Portal – Quota Points

Role Subscription 1010630 Admin

Creation Source
Select a template from which to create the virtual machine.

Name	Description	Operating System	NIC	Memory	Disk	Quota points
W2k8R2-1G		64-bit edition of Windows ...	1	102...	80...	2
W2k8R2-2G		64-bit edition of Windows ...	1	204...	80...	4

System Configuration
Apply properties to this computer

Name: Computer name:

Description: Admin password:

Confirm password:

Product Key:

Quota Points
Total (40) Used (2) Available (38)

When all data filled you can create VM

For each VM template
Provider defines cost in unified
measure - Quota Points

Customer can see Total, Used and
currently Available Quota Points –
according to chosen Service
Package



Microsoft Hyper-V Cloud Service Packages – Changing

Hyper-V Account (Account ID: 1002872) Parallels Automation

Subscription: 1010630

Configuration & Admin...

Domain Overview

Microsoft Hyper-V

About

Management

Statistics & Analysis

All Domains | Hosting | My Account | Help & Support | Billing Logout

Hosting » Configuration & Administration » Microsoft Hyper-V Management

Screen ID: 2.12.12.06.01 Refresh

Use Microsoft Hyper-V Virtual Machine Manager to create, remove and configure your Virtual Machines.

Virtual Machine Manager [Login G+](#) [Change](#)

Status **Configuring**

Login PRL4\hvd_demo_account

Password Wilmt6zP

Service Package **Hyper-V Hosting - Advanced** [Change](#)

(Unexceptional offering for your dynamic datacenter - run up to 40 Windows or Linux Virtual Machines for just \$500 a month)

Service Package can be changed any time

Hyper-V Account (Account ID: 1002872) Parallels Automation

Subscription: 1010630

Configuration & Admin...

Domain Overview

Microsoft Hyper-V

Statistics & Analysis

Resource Usage

All Domains | Hosting | My Account | Help & Support | Billing Logout

Hosting » Configuration & Administration » Statistics & Analysis Resource Usage

Screen ID: 2.21.05.04 Refresh

see it here

Search for:

Available

ID	Resource ▲	Usage	Limit	Available	Last update
1015777	Hyper-V Application	1 unit	1 unit	0 unit	Feb-14-2011 15:21
1015779	Application Backup	0 unit	1 unit	1 unit	Feb-14-2011 15:21
1015778	Application User	0 unit	1 unit	1 unit	Feb-14-2011 15:21
1015785	Hyper-V Hosting - Advanced	1 unit	1 unit	0 unit	Feb-14-2011 16:06
1015783	Hyper-V Hosting - Basic	0 unit	1 unit	1 unit	Feb-14-2011 16:06
1015781	Hyper-V VMs	0 KB	Unlimited	Unlimited	Feb-14-2011 15:21

Billing System charges for time each package is used

© Copyright 1999-2010 Parallels All rights reserved



PCI Compliance & SDK

Audited Security

- Application, Code and Processes audited by Trustwave provides peace of mind to Parallels Automation partners

Faster PCI Compliance

- With PA-DSS compliance Parallels Automation partners can complete their own PCI compliance faster and easier

SDK for Domain Plug-ins

- Providers, Integrators and Registrars can easily extend PBA themselves by writing custom Domain plug-ins



Promotions & Billing

Percentage-based Promos

- Run more flexible promotions with a mix & match of percentage discounts and fixed price

Promos for Add-Ons

- Create promotions on Resource-level to offer special pricing for add-ons like mailboxes or disk space

Bill for external Services

- Bill for any external services through PBA and provide your customers a single point for invoices and payments



User Experience Improvements

Focus on **end-to-end scenarios**

Introduced usability improvement process involving partners

Customer Dashboard

- **New customer dashboard** provides a clear overview on the account and single entry point for frequently used functions.

Wizards and scenarios

- Multiple **new wizards** were created to improve the top usage scenarios provided by Automation partners.

Localization

- Updating product descriptions with up to 8 languages conveniently from a single screen



PA Usability Improvements: PBA 5.0 Customer CP

Many iterations of design and review while creating new main screen for PBA Customer CP

The screenshot shows the Parallels Billing Manager interface. The top navigation bar includes the Parallels logo and the text "Parallels Business Automation". The main content area is titled "Billing Manager" and includes a "Top" link and "Screen ID: 1.22.0.11" with "Help | Refresh" links. A sidebar on the left lists navigation options: "Billing Manager", "Domain Management", "Subscription Management", "Upgrade Wizard", "My Financial Info", "My Contact Info", and "My Tickets". The main content area is divided into several sections: "My Status" (Orders and Invoices) showing "Unpaid \$120" with a "Pay Now" button, "Open and Pending: 4", and "Auto payments: On"; "My Account" (Financial Management) with options like "New Payment", "New Credit Card", "List Invoices and Payments (35)", and "Manage Payment Methods (0)"; "Account Management" with "New User" and "Edit Account Info"; "My Services" (Subscription Management) with "Subs...", "ins (3)", and "ource"; and "Domain Management" with "Register New Do..." and "Transfer...". Three red callout boxes are overlaid on the interface: one pointing to the "Unpaid \$120" status, another pointing to the "Financial Management" section, and a third pointing to the "Domain Management" section.

Quick access to critical information

All major tools on one screen

New CCP Dashboard



PA Usability Improvements: New PA UI

PA UI core layouts redesigned, new default skin

Old UI

The screenshot displays the old PA UI for 'Dotster, Inc.'. At the top, there is a navigation bar with 'Top' and 'Dotster, Inc.' on the left, and 'Screen ID: 1.00.00.01', 'Edit Help box', 'Refresh', and 'Help' on the right. Below the navigation bar are two tabs: 'Summary' and 'General'. The main content area is divided into several sections:

- General:** Contains fields for 'ID: 1', 'Name: Provider, Inc.', and 'State: Enabled'. To the right are links for 'Edit Company Info' and 'Edit Contacts'.
- Accounts:** Contains fields for 'Resellers: 2' and 'Customers: 23'.
- Services:** Contains a field for 'Domains: 14' and a link for 'Add Existing Domain Registered Elsewhere'.
- Hosts:** Contains a field for 'Hosts: 4567' and a link for 'Install hardware node'.
- Last Login:** Contains fields for 'IP Address: 10.10.10.10' and 'Date: Feb-09-2011 06:35', with a link for 'Login History'.



PA Usability Improvements: New PA UI

PA UI core layouts redesigned, new default skin

New UI

The screenshot displays the 'Order #3343434' page in the new PA UI. The interface includes a breadcrumb trail (Top > My Financial Info > Orders), a title bar, and a navigation menu with tabs for 'General', 'Payments', 'Users', and 'Other Subscriptions'. A 'Summary' bar is located below the tabs. The main content area is divided into sections: 'Order Summary Information' with document generation options, 'Attached Documents' with search filters, and a table of document details. Annotations with red arrows point to specific UI changes: 'Removed unnecessary icons' points to the top navigation area; 'Improved tab bar' points to the 'Payments' tab; 'Redesigned buttons' points to the 'New Invoice', 'New Payment', 'Pay Orders', and 'Cancel' buttons; and 'Improved navigation' points to the table's pagination and sorting controls.

Top > My Financial Info > Orders
Order #3343434
Screen ID: 00.02.02
Help | Refresh

Users | Other Subscriptions | Some Other Subscriptions
General | Payments | Users | Other Subscriptions
Summary | Advanced Settings | Support

Removed unnecessary icons

Improved tab bar

Redesigned buttons

Improved navigation

Order Summary Information

Single Document htmldoc --no-embedfonts --quiet --webpage -f @@DstName@ @@SrcName@ Print
Mass Generation htmldoc --no-embedfonts --quiet --webpage -f @@DstName@ @@SrcName@

Attached Documents

Number Type Status
Search For: Invoice Invoice Search Reset Results

New Invoice New Payment Pay Orders Cancel

1 - 40 of 3169 Next> Last>> On page: 25 50 100 Select Columns Export to Excel

<input type="checkbox"/>	Document	Date	Num	Type	Status	Total	Comments
<input checked="" type="checkbox"/>	12-Jan-2010	005		Sales Order	Waiting for Payment	\$3.00	Upgrade/Downgrade of Resources
<input type="checkbox"/>	12-Jan-2010	004		Sales Order	Waiting for Payment	\$100.00	Recurring Fee
<input type="checkbox"/>	12-Jan-2010	004		Sales Order	Waiting for Payment	\$100.00	Recurring Fee

1 - 40 of 3169 Next> Last>> On page: 25 50 100 Select Columns Export to Excel

Configure Disable Cancel Delete



PA Usability Improvements: New PA UI

Improved usability of PBAS Online Store

New Order

Steps: 1 Domains 2 Package 3 Sign In/Register 4 Configuration 5 Checkout 4 Payment

Your Shopping Cart

Package: (select)
Not Selected

Domains: (add more)

reseller.com × 1 Years \$100

more.tv × 1 Years \$100

Total: \$100

Checkout Cancel

Virtual Private Servers

Virtuozzo Linux Hosting	Subscription Period	Setup Fee	Subscription Fee	Total	
VPS Linux Pro Super puper plan for VPS lovers!	1 Month(s)	\$20	\$10 / Month	\$30	Order
	6 Month(s)	\$15	\$8 / Month	\$63	Order
VPS Linux Pro Super 2000 Only for professionals. High price for high service.	1 Month(s)	\$20	\$10 / Month	\$30	Order
	6 Month(s)	\$15	\$8 / Month	\$63	Order

Virtuozzo Windows Hosting	Subscription Period	Setup Fee	Subscription Fee	Total	
VPS Win Pro Super puper plan for VPS lovers!	1 Month(s)	\$20	\$10 / Month	\$30	Order
	6 Month(s)	\$15	\$8 / Month	\$63	Order
VPS Win Pro Super 2000 Only for professionals. High price for high service.	1 Month(s)	\$20	\$10 / Month	\$30	Order
	6 Month(s)	\$15	\$8 / Month	\$63	Order

Plesk Domain Hosting

Hosting Plan	Subscription Period	Setup Fee	Subscription Fee	Total	
Plesk Domain Linux Super puper plan for VPS lovers!	Trial 1 Month(s)	\$0	\$0	Free	Order
	6 Month(s)	\$15	\$8 / Month	\$63	Order
	1 Year(s)	\$10	\$50 / Year	\$60	Order
Plesk Domain Linux with Sitebuilder Only for professionals. High price for high service.	1 Month(s)	\$20	\$10 / Month	\$30	Order
	6 Month(s)	\$15	\$8 / Month	\$63	Order
	Promotion!	\$10	\$7 / Month	\$63	Order

Back Skip Package Selection



Parallels Business Automation Standard

Two releases in the past 6 months (3.4 and 4.0)

PBAS 3.4

Support for Parallels Server Bare Metal and Parallels Server for Mac

- Sell-up, enables Hypervisor based offerings

Improvements to Online Store

- Improved Look and Feel, Usability of Purchase Wizard reduces Purchase Dropout

Support for 3-D Security in PayPal

- More Security/Integrity for PayPal Transactions

License Key Provisioning for Parallels Plesk Panel 9.5

- Sell-up, enables PBA-S to support latest and greatest Panel

IDN TLD support for Dummy Plug-in

- Support for International TLD for manual 'offline' domain registration: supports National characters in Domain and IDN



Parallels Business Automation Standard

PBAS 4.0

SSL Certificates Provisioning

- Up-sell with certificates. eNom built-in! Dummy SSL plug-in enables other Certificates manually

Integration with Parallels Operations Automation

- Offer Microsoft Hosted Exchange. Expand offerings as more Services are enabled over time

Parallels Plesk Panel 10.1 Support

- Shared Hosting and now automated provisioning of Panel 10.1 licenses with PVC with Panel 10.1 pre-installed



Parallels Business Automation Standard

PBAS 4.0

Licensed Applications to Offer Your Customers via PBAS Online Store

- UNITY Mobile, Pinnacle Cart, MyLittleAdmin, Acronis Backup, Parallels Premium Antivirus, Parallels Plesk Panel Anti-Virus Powered by Kaspersky, MagicSpam

Hosting Plans Upgrade Rules

- Optionally allows for more control/limiting a set of hosting plans that are compatible for upgrade



Parallels Automation in 2011



Goals for Parallels Automation in 2011

Broader range of services – Help to become full service providers

- Microsoft Hyper-V
- Office 365
- Cloud Infrastructure (C2U)
- Hosted PBX
- 25 new business apps

Help service providers to run business more efficiently

- Bulletproof upgrades
- Usability improvements
 - Storefront experience
 - Reseller wizard
- IPv6
- PA on Demand



2011 - Latest Microsoft Products

Exchange 2010 SP1 Hosting Mode

- Cross-domain mailbox migration tools:
 - From Exchange 2003, 2007, 2010 Enterprise
 - Will handle Blackberry accounts migration

Microsoft SharePoint Foundation 2010

- Migration from Windows SharePoint Services 3.0

HMC replacement: WPE

- Better platform:
 - Windows Server 2008 R2 x64
 - High Availability / Load Balancing
- Long-term solution for Unified Communications provisioning



Exchange 2010 SP1 Hosting Mode

Better tenant isolation

Better address book architecture

Supports third-party products and services:

- Blackberry
- MX Logic
- MessageLabs
- Postini

Not compatible with HMC

- Requires alternative provisioning engine

Cannot share AD domain with Exchange 2007



Lync (OCS 2010)

Enterprise Version: Not planned

- Already released
- Supports both Remote Call Control and Enterprise Voice
- **No official support for multi-tenancy**

Hosting Version: Depends on MS release

- MS Release ETA is Dec 2011
- **Feature set not known yet**
- Native tenant isolation
- Not compatible with HMC



Further Extending of DDCTK-h Integration

Enabling individual VM configurations for sale

- In addition to “service packages” (released in 2010), customers order individual VM configuration in PA store (CPU, RAM, Disk, OS, VM Template)
- Automated VM provisioning, management directly from PA Customer Control Panel
- Upselling particular VM parameters: CPU, RAM, Disk
- Traffic accounting and billing for it

Automated installation of Parallels Plesk licenses if they ordered with VM

VM Backup and Restore

Extending PA operations capabilities for Provider's staff

- Lookup VM by customer, subscription, IP
- Check VM configuration, operate it directly from PA UI

Billing for compute resources used daily



Suggest reducing content, or breaking into 2 slides for readability



PA for Cloud Infrastructure

Intuitive Server Configurator & API

- Attract more customers by allowing them to **order and resize Cloud Servers** through intuitive configuration screens
- Customer can also create/resize/destroy servers through new **REST API**

Hourly Billing

- Be more flexible by offering billing based on **hourly usage**. Customers pay only for their real usage

Enhanced Infrastructure

- Choose to run **Containers or VMs**
- **Private networks** to securely connect multiple servers of one customer



Parallels Office 365 Syndication

New Services

Blackberry & Trial Subscriptions

Support of new Office 365 Offers and Services

Bundling Office365 services with:

- Third party mail archiving support
- Third party anti-spam and antivirus filters support
- Third-party Voice Support

Limitations:

- Limited support of PowerShell cmdlets

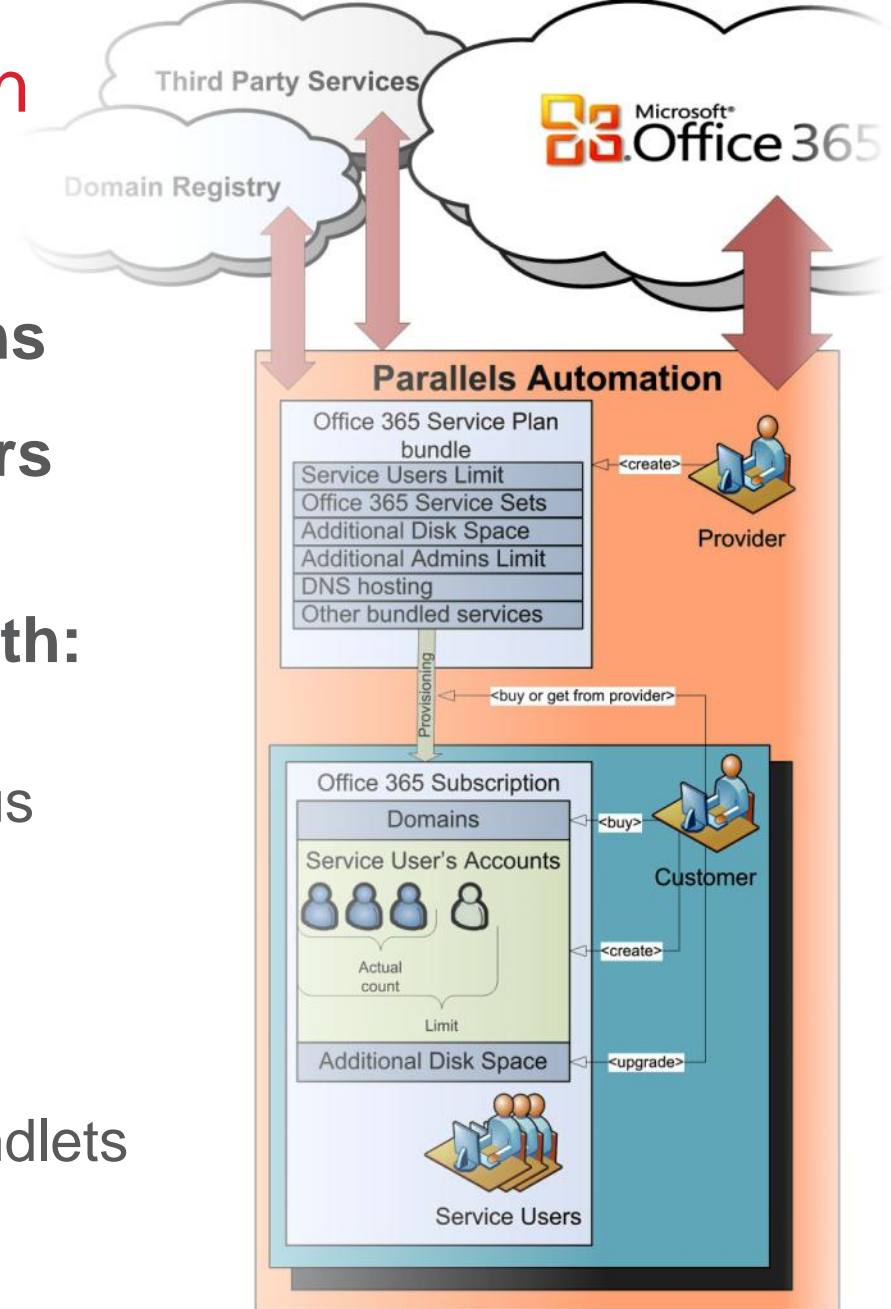

Parallels Office 365 Syndication

New Features

Autologin to Office 365 portal and OWA

Migration from on-premise Exchange support

Transitions of existing BPOS customers to Office 365

Limitations:

- Managing of distribution lists, contacts, SharePoint Sites on MS Admin Portal only

Autologin to Outlook Web Access



Migration from On-Premise Exchange Support

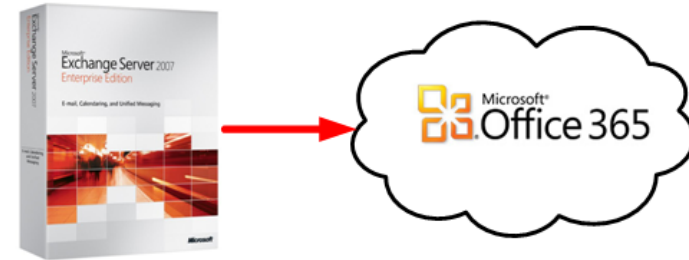

Transitions of existing BPOS customers to Office 365

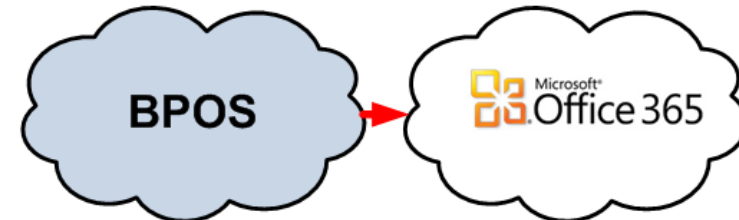

Limitations – Managing on MS Admin Portal only

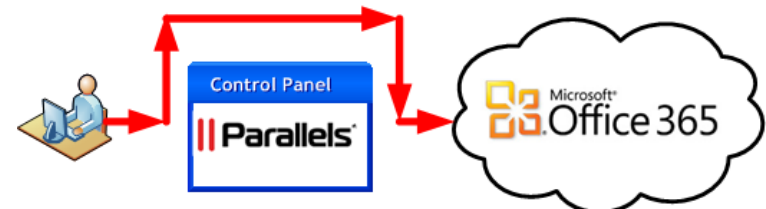

25 New Applications

Commercial Apps



SMB Categories



PA on Demand by SoftLayer

Parallels

- Parallels Automation Software
- Configuration

SoftLayer

- Hardware
- Connectivity
- Datacenter Hosting

Core Offerings

- PBA + POA

Options

- VPS (Linux / Windows)
- Shared (Linux Windows)
- SaaS

Bundles

- Exchange+SharePoint



2011 – Hosted PBX

Traditional Hosting Services

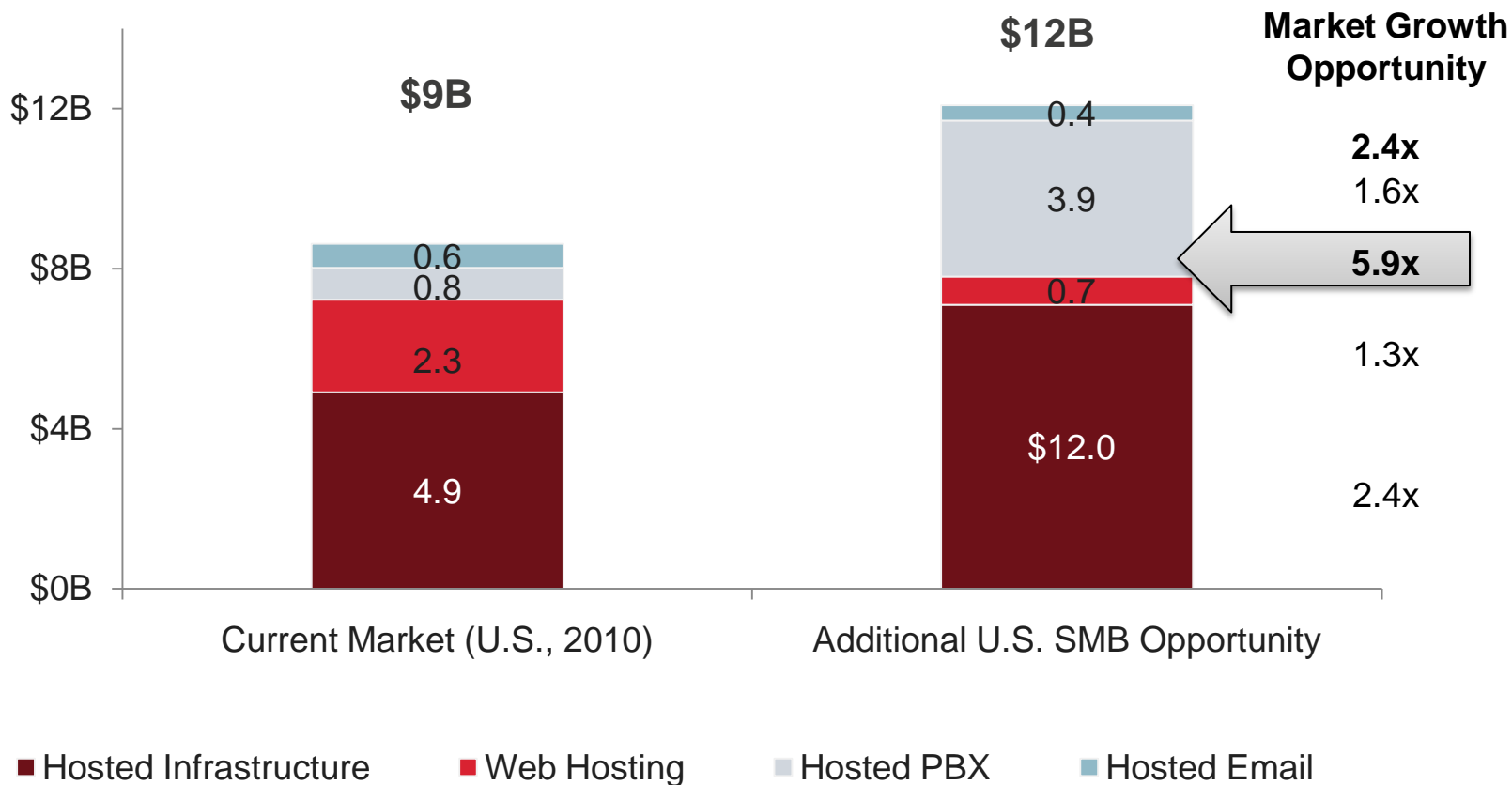

Note: Opportunity analysis includes effect of SaaS on hosted and in-house server consumption over a 3-5 year time period
 Source: Parallels SMB Cloud Insights (U.S., 2010)



Hosted PBX Benefits

Traditional PBX	Hosted PBX
Expensive PBX Equipment	No on-site phone system
Costly Business Lines	Hosted service
Costly rewiring to move or add employees	Online portal to move and add employees
Scalability limited without cost	Easy and inexpensive to upgrade
Inflexible for mobile workers	Remote worker and teleworker support
Equipment quickly becomes outdated	Future-proof software upgradeable system



Why BroadSoft?



World's leading business solution:

- In **425+ service providers** in 65 Countries
- Deployed in **15 of top 25** worldwide service providers
- **8M seats** deployed

Complete PBX feature set for businesses of any size

- 100s end-user features;
- 10s company features

Built-in multi-tenancy support



Hosted PBX Featureset

What – Features

- IP Phones Management
- Public Numbers Management
- VoiceMail Support
- Personal Call Forwarding Support
- Response Groups Support
- Time-Based Routing Support

For SMB Customers

- Enterprise PBX features without upfront investments
- Pay as you grow
- Tightly integrated with other messaging and collaboration services



Channel Management

Reseller Setup

- With the new intuitive setup wizard Resellers can go live in a matter of minutes.
- Resellers can use the same wizard to quickly adjust their business in future.

Branding

- Full private URL branding for billing control panel provides customers of Resellers with higher Reseller brand identification.

API

- Resellers can use new REST based API to access billing data for integration with own external systems (e.g. online store or ERP system)



Windows 2008 R2 64-bit

Why Windows 2008 R2 64-bit

- Compatibility with latest Windows 2008 R2 g continuous support from Microsoft
- 64-bit provides better scalability

Management software

- Parallels Automation management software to run on Windows 2008 R2
- SQL Server 2008 as database backend

Application Services

- Exchange 2010 SP1
- Hyper-V Virtual Machines
- SharePoint
- Windows Shared Hosting (IIS)



IPv6

Q2 2010

- Basic IPv6 support
 - IPv6 pools
 - AAAA DNS records
- Linux Shared Hosting NG
- External IPv6 Systems (Domain Registrars, Payment Gateways, External Helpdesks) Support in PBA

Q4 2011

- Windows Shared Hosting
- Linux VPS Hosting
- Windows VPS Hosting
- Microsoft Hyper-V VMs

2012

- Customer Panel, Branded Access Points

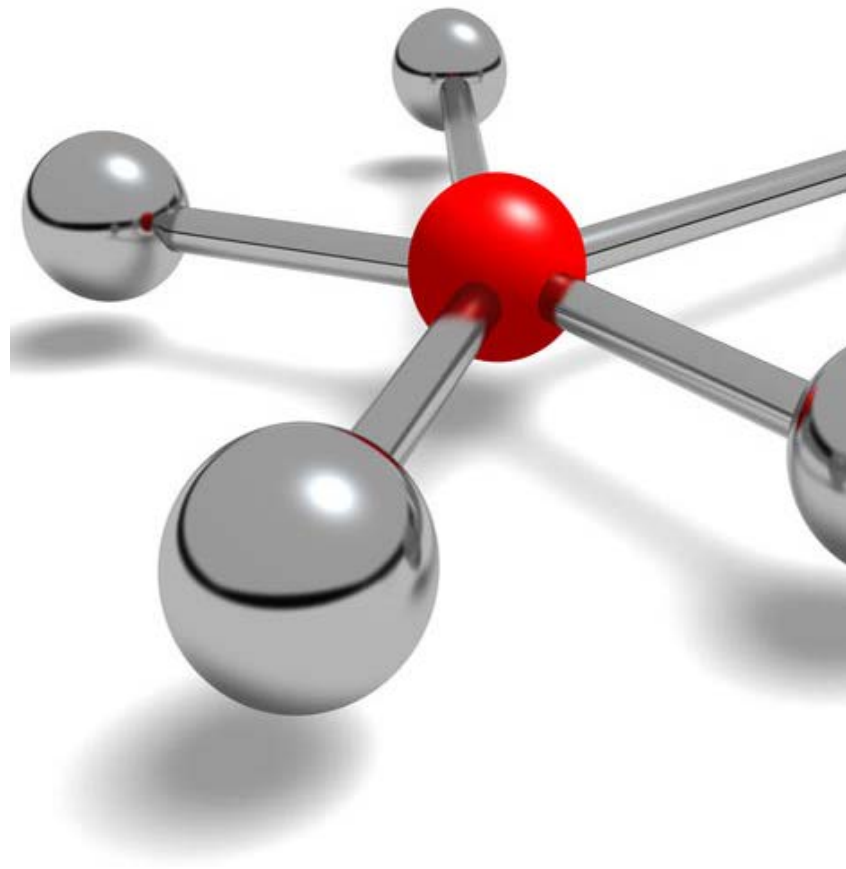

User Experience Improvements Example

Reseller Wizard

[Top](#)
Initial Setup

Screen ID: 00.02.02

[Help](#) | [Refresh](#)

1 Account 2 Plan Set 3 **Plan Prices** 4 Resource Prices 5 Online Store 6 Control Panel 7 Final

Select the service plan periods you want to resell and adjust base pricing. Periods have been grouped by plan and plan category.

Service Plan Periods

Adjust Selected Prices By X %

Reset Selected Prices To Provider Default

Period	Recurring Fee	Margin	Renewal Fee	Margin	Transfer Fee	Margin	Currency
<input type="checkbox"/> Power H							
<input type="checkbox"/> Linux P							
<input checked="" type="checkbox"/> 1 month	0.00	0%	0	0%	0	0%	USD
<input type="checkbox"/> 6 month	0.00	0%	0	-100% (src 1.00)	0	0%	USD
<input type="checkbox"/> Window							
<input type="checkbox"/> 1 month(s)							USD
<input type="checkbox"/> 6 month(s)							USD
Mail Hosting Plans							
Linux Mail							
<input checked="" type="checkbox"/> 1 month(s)	10	20% (src 8.00)	2	200% (src 0.00)	0	0%	USD

Increase Prices

Here you can increase the selected prices by some percent.

Increase By %

Apply

Back

Save and Continue





User Experience Improvements Example

Redesigned POA CCP Hosting Dashboard

[Top](#) **Hosting** Screen ID: 1.22.0.11
[Help](#) | [Refresh](#)

This screen provides your a hosting information and tools.

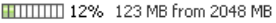
Current Subscription

Subscription	Linux Hosting + Saa5 (ID:123344)	Change
Disk Space	 12% 123 MB from 2048 MB	
Traffic	 90% 9 GB/Month from 10 GB/Month	

[Resource Usage](#) [Buy More Resources](#)

Current Webspace

Webspace	super43434.com (ID:65656566)	Change
SSL	<input checked="" type="checkbox"/> Enabled	Configure
FTP Access	<input type="checkbox"/> Disabled	Manage Files Configure
File Manager	<input checked="" type="checkbox"/> Enabled	HTTP Docs HTTPS Docs Configure
SSH Access	<input type="checkbox"/> Disabled	Configure

Tools

Domains

[Domains](#) [Add New Domain](#) [Add New Subdomain](#)

Hosting

[Content Management](#) [Website](#) [HTTP Documents](#) [HTTPS Documents](#) [More Hosting Tools...](#)

[Close](#)

Email

[Mailboxes](#) [Mailists](#) [Add New Mailbox](#) [New Maillist](#)

Advanced

[Add New Service User](#) [Add New Staff Member](#) [Applications](#) [More Advanced Tools...](#)



User Experience Improvements Example

Improved PBA Online Store

Hosting Store

Order Cloud Server

Steps: **1. Configuration** | 2. Domains | 3. Account | 4. Checkout

Your flexible, independent, and unique server solution!
Dedicated server environment with full root access. Adjust the amount of processor cores, RAM, and/or hard disk storage space whenever necessary. Linux or Windows operating system, 24/7 Customer Support.

Build Your Own Virtual Environment

Resource Configuration: **Custom** | Basic Server | Power Server | Mega Server | Compare

Disk Space: **2 GB**



\$12.00 per Month
\$0.016 per Hour

RAM: **1024 MB**



\$23.00 per Month
\$0.03 per Hour

CPU: **4 Core(s)**



\$3.00 per Month
\$0.01 per Hour

Operating System:

- Linux
- Windows

Software Included:

Plesk 9

\$3.00 per Month
\$0.01 per Hour

Backup Period:

Daily

\$4.00 per Month
\$0.01 per Hour

Advanced Settings ▾

- I will manage the OS kernel (2)

Total Estimated Price per Month : \$57.00

Total Price per Hour: \$0.0779

[Cancel Order](#)

[Add To Order »](#)

Your Order

Cloud Server	\$0
mycompany.com	\$20

Total: \$20

*prices without taxes
and promo discounts



Stability & Performance

- Boost Performance with the latest database versions support
 - Microsoft SQL Server 2008
 - PostgreSQL 9.0
- Big Step to High Available Solution
 - POA Management Node & UI Auto-Provisioning
 - POA & PBA Database Servers
- Automation Platform Improvements
 - POA Task Manager
 - PBA Muxer & Transaction Manager
 - PBA Transport Protocol
- New internal QA procedures
 - Total Stability Monitoring
 - Week Load Test
 - Automated Performance Testing



PBAS Plans in 2011

Major directions of development for this year

Up to date support of Parallels products

- Support for Parallels Virtuozzo Containers 4.6
- Support for Parallels Server Bare Metal 5.0

Standards Compliance

- Full support for IPv6 infrastructure
- PCI compliance

Billing Improvements

- Consolidated invoicing
- Support for tokenized credit card payments



Summary

New services

- Office 365
- Hyper-V
- Hosted PBX
- Application Hosting
- IPv6

Talk to your Parallels Account Managers



Thank you!

Feedback always welcome: om@parallels.com

